

THIS DRAWING IS UNPUBLISHED. RELEASED FOR PUBLICATION, 19
 © COPYRIGHT 19 BY AMP INCORPORATED, HARRISBURG, PA. ALL INTERNATIONAL RIGHTS RESERVED. AMP PRODUCTS MAY BE COVERED BY U.S. AND FOREIGN PATENTS AND/OR PATENTS PENDING.

LOC	DIST	P	F	REVISIONS				
				ZONE	LTR	DESCRIPTION	DATE	APPROVED
AF	50				AR	REACT -4 PER 0L10-0228-96	12/11/96	JR/PD

1 CONTINUOUS STRIP ON REELS.
 2 PART TO BE PUT ON PLASTIC REELS.

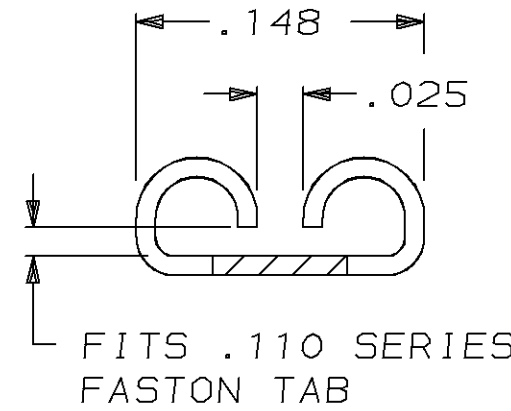
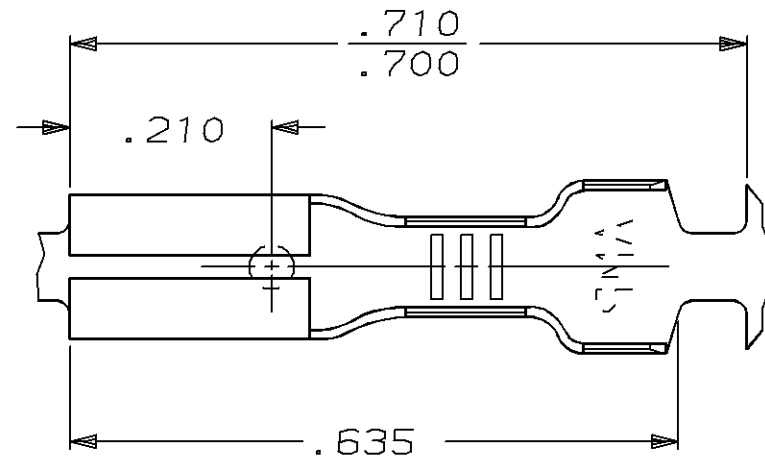

VIEW A-A

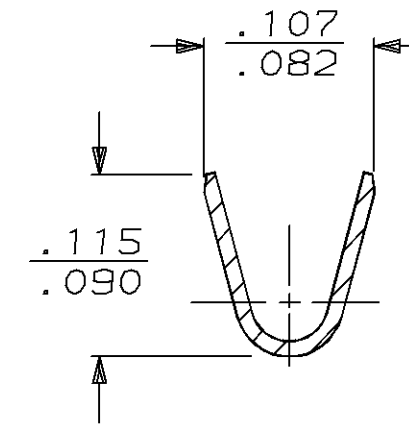

SECTION B-B

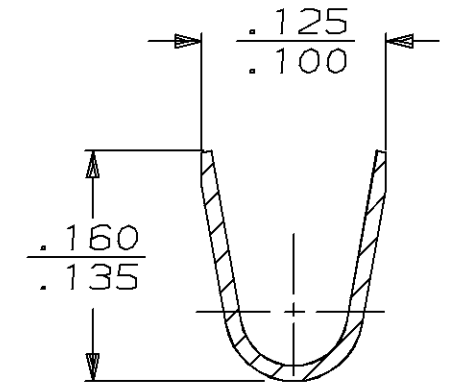

SECTION C-C

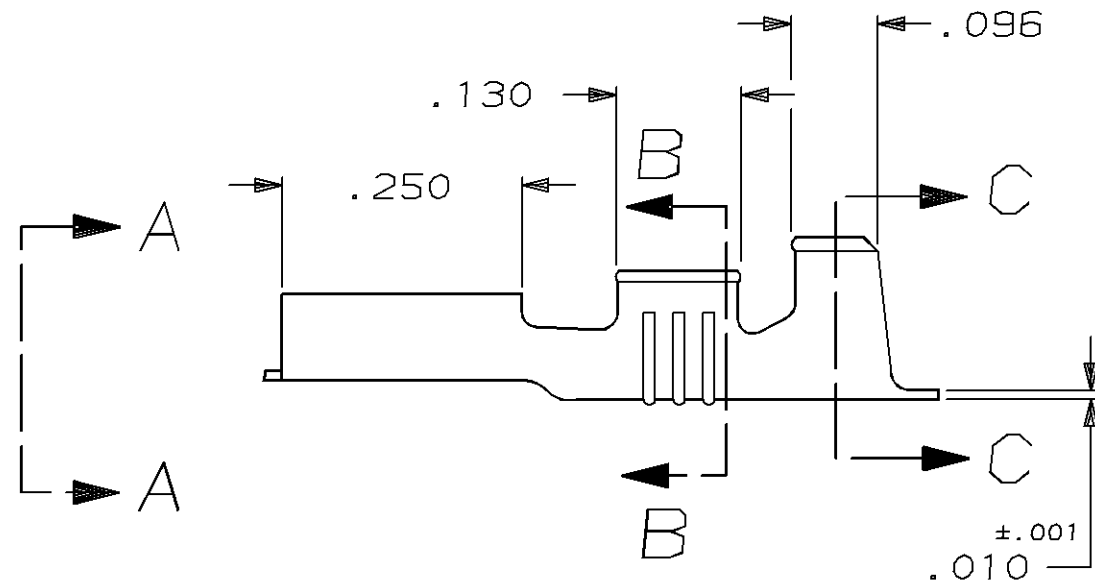

OBSOLETE

PRE-TIN	#4H BRASS	.060-.100	22-18	.016	60118-4 2
SILVER	#4H PHOS BRZ	.060-.100	22-18	.016	60118-2
PRE-TIN	#4H BRASS	.060-.100	22-18	.016	60118-1
FINISH	MATERIAL	INSUL RANGE	WIRE SIZE	MATING TAB THK ±.001	PART NO

UNLESS OTHERWISE SPECIFIED DIMENSIONS ARE IN INCHES TOLERANCES ON:
 2 PL DEC ± -
 3 PL DEC ± .015
 ANGLES ± -

DR	6/23/87	JR RUTH
CHK	6/23/87	G YETTER
APPD	6/23/87	C MEYERS
APPD	6/23/87	R KUZO
MATERIAL	SEE TABLE	PRODUCT SPEC
FINISH	SEE TABLE	APPLICATION SPEC
WEIGHT	-	-

AMP INCORPORATED Harrisburg, Pa. 17105		
NAME RECEPTACLE, FASTON, TM .110 SERIES		
SIZE B	FSCM NO 00779	DRAWING NO 60118
SCALE NTS	SHEET 1 OF 1	